

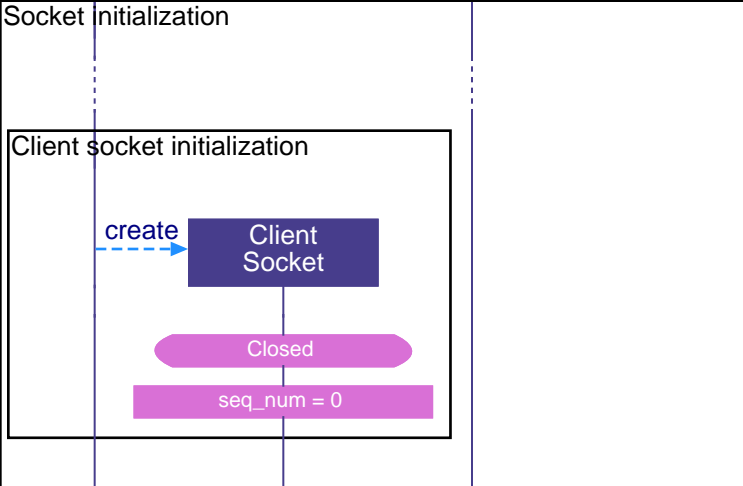

This sequence diagram was generated with EventStudio System Designer (<http://www.EventHelix.com/EventStudio>).

We have already seen that TCP connection starts up in slow start mode, geometrically increasing the congestion window (cwnd) until it crosses the slow start threshold (ssthresh). Once cwnd is greater than ssthresh, TCP enters the congestion avoidance mode of operation. In this mode, the primary objective is to maintain high throughput without causing congestion. If TCP detects segment loss, it assumes that congestion has been detected over the internet. As a corrective action, TCP reduces its data flow rate by reducing cwnd. After reducing cwnd, TCP goes back to slow start.



Server awaits client socket connections.

Client Application creates Socket

The socket is created in the Closed state

Initial sequence number is set to 0

Active\_Open

Application wishes to communicate with a destination server using a TCP connection. The application opens a socket for the connection in active mode. In this mode, a TCP connection will be attempted with the server. Typically, the client will use a well known port number to communicate with the remote Server. For example, HTTP uses port 80.

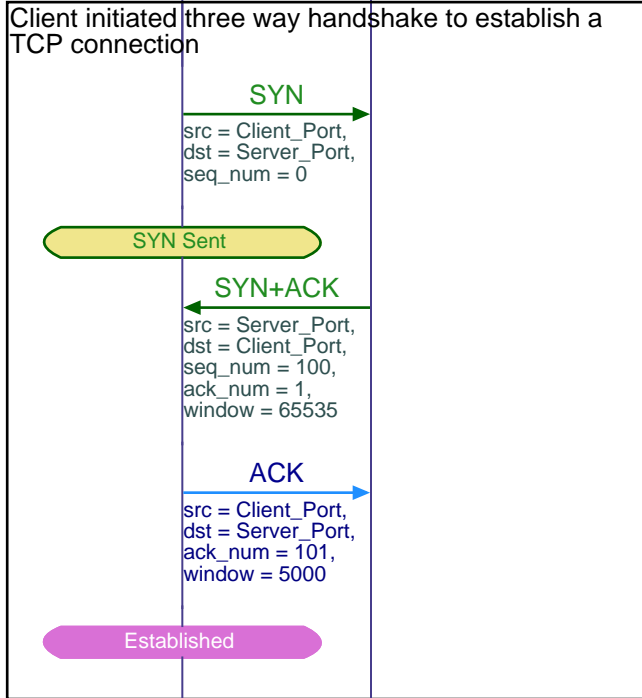

Client sets the SYN bit in the TCP header to request a TCP connection. The sequence number field is set to 0. Since the SYN bit is set, this sequence number is used as the initial sequence number

Socket transitions to the SYN Sent state

Client receives the "SYN+ACK" TCP segment

Client now acknowledges the first segment, thus completing the three way handshake. The receive window is set to 5000. Ack sequence number is set to 101, this means that the next expected sequence number is 101.

At this point, the client assumes that the TCP connection has been established

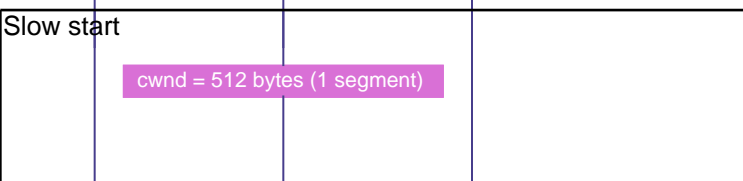

TCP connection begins with a congestion window size of 1 segment

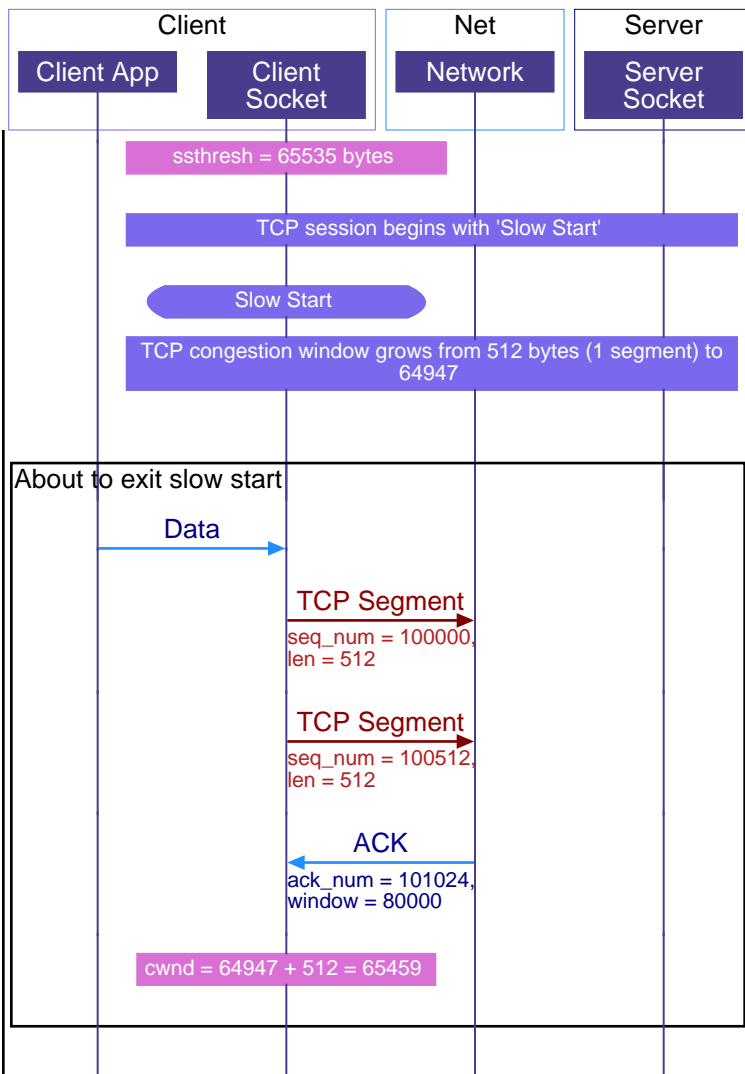

The slow start threshold starts with 64 Kbytes as the threshold value.

Click on the action title for a detailed description of the TCP slow start.

Since  $cwnd < ssthresh$ , TCP state is slow start

TCP congestion window grows at the start of the session if no segment losses are detected during slow start). During slow start the congestion window was being incremented by 1 segment for every TCP Ack from the other end.

Client Application sends data for transmission over the TCP Socket

Data is split into TCP Segments. The segments are sent over the Internet

Since TCP is in slow start, every ack leads to the window growing by one segment.

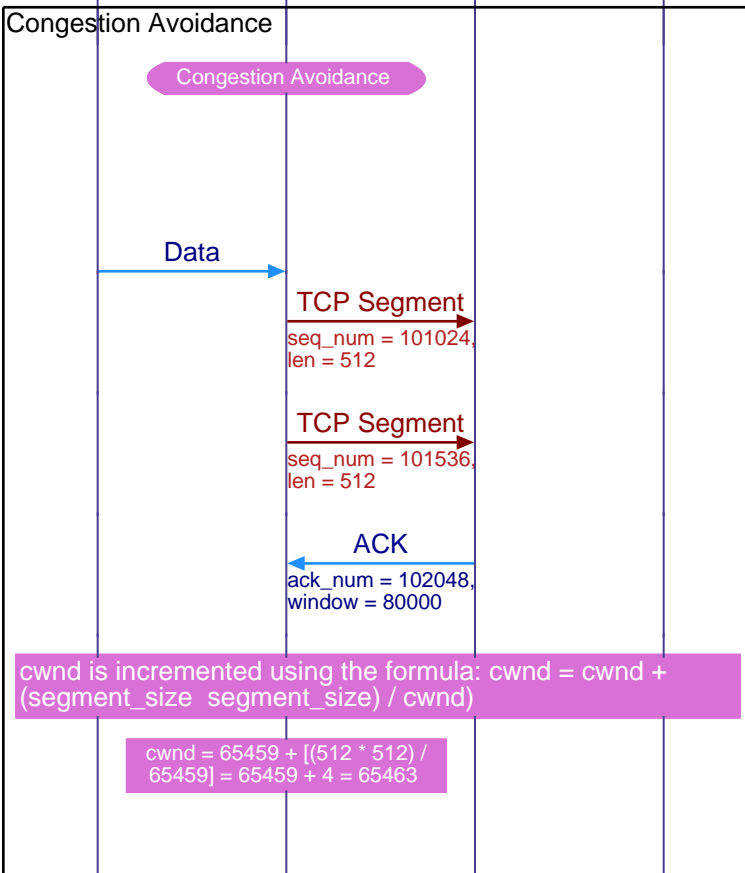

At this point  $cwnd (=65459) > ssthresh (=65535)$  thus TCP changes state to congestion avoidance. Now TCP window growth will be much more conservative. If no segment or ack losses are detected, the congestion window will grow no more than one segment per roundtrip. (Compare this with geometric growth of 1 segment per TCP ack in slow start)

More data is received from the client application

Client data is split into TCP segments

Now TCP is in congestion avoidance mode, so the TCP window advances very slowly. Here the window increased by only 4 bytes.

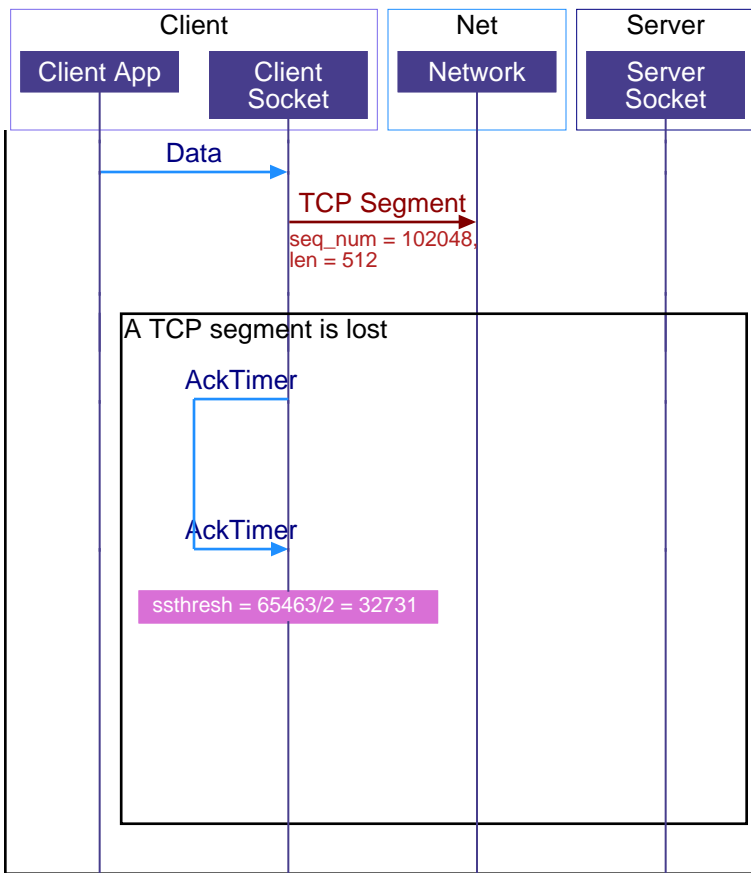

Data to be sent to server

TCP session sends out the data as a single segment

TCP session starts a ack timer, awaiting the TCP ack for this segment.  
 Note: The above timer is started for every segment. The timer is not shown at other places as it does not play a role in our analysis.

TCP times out for a TCP ACK from the other end. This will be treated as a sign of congestion by TCP

When TCP detects congestion, it stores half of the current congestion window in ssthresh variable. In this case, ssthresh has been reduced from 65535 to 32731. This signifies that TCP now has less confidence on the network's ability to support big window sizes. Thus if the window size falls due to congestion, rapid window size increases will be carried out only until the window reaches 32731. Once this lowered ssthresh value is reached, window growth will be much slower.

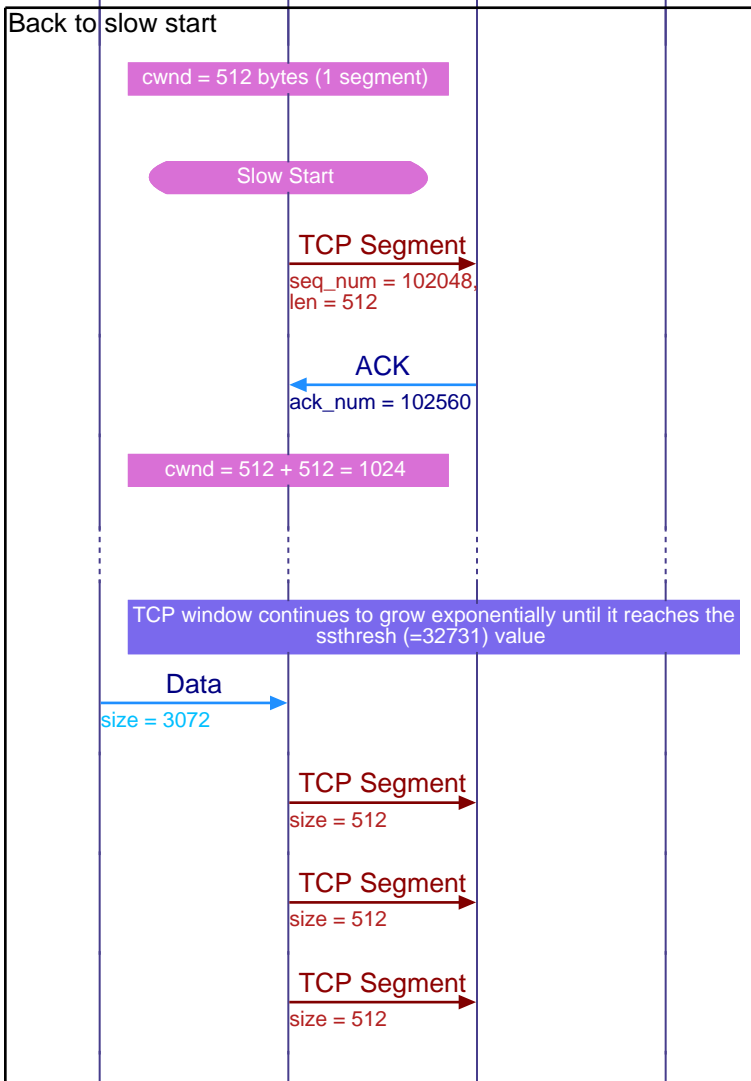

Since current congestion has been detected by timeout, TCP takes the drastic action of reducing the congestion window to 1. As you can see, this will have a big impact on the throughput.

cwnd (=1) is now lower than ssthresh (=32731) so TCP goes back to slow start.

Since TCP is in slow start, a TCP acknowledgement results in the window growing by one segment

Six TCP segments are transmitted in the slow start mode

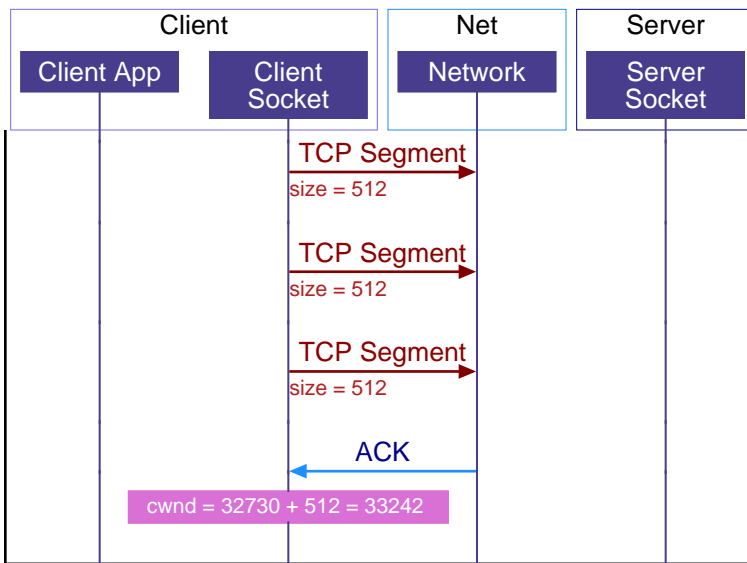

Ack for the first two segments is received

TCP is in slow start so the congestion window is increased by one segment

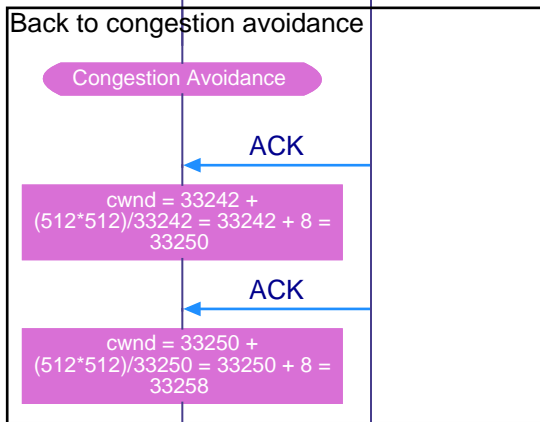

Now  $cwnd (=33242) > ssthresh (=32731)$ , thus the TCP session moves into congestion avoidance

Ack for the next two segments is received

Now the TCP window is growing very slowly by approximately 8 bytes per ack

Ack for the last two segments is received

Congestion window continues to advance at a slow rate

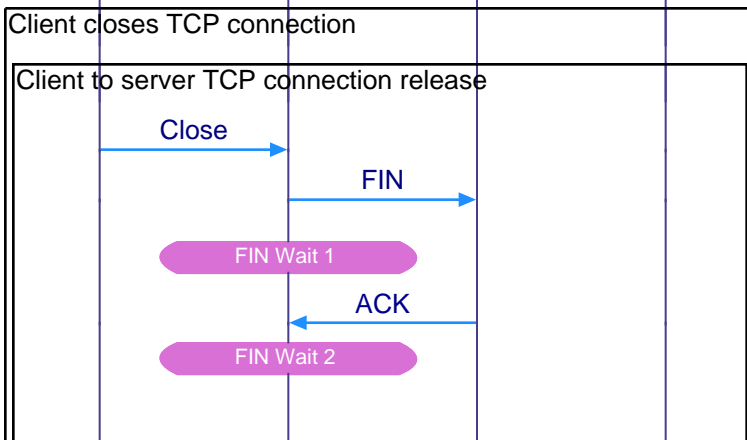

Client application wishes to release the TCP connection

Client sends a TCP segment with the FIN bit set in the TCP header

Client changes state to FIN Wait 1 state

Client receives the ACK

Client changes state to FIN Wait 2. In this state, the TCP connection from the client to server is closed. Client now waits close of TCP connection from the server end

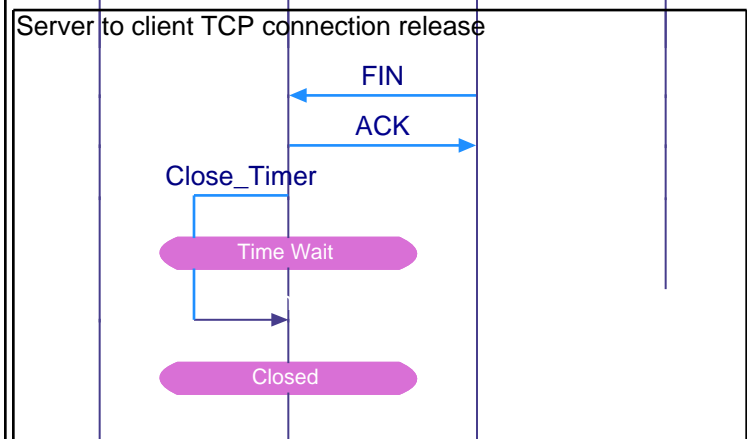

Client receives FIN

Client sends ACK

Client starts a timer to handle scenarios where the last ack has been lost and server resends FIN

Client waits in Time Wait state to handle a FIN retry

Close timer has expired. Thus the client end connection can be closed too.

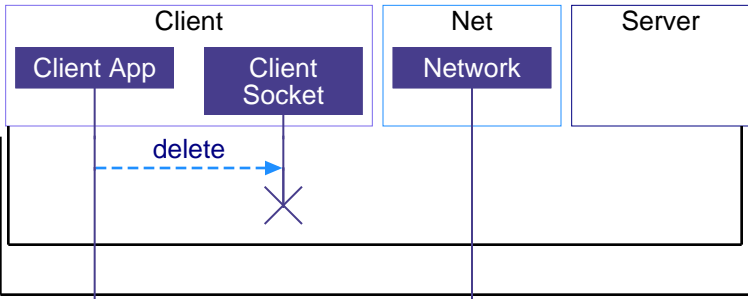

This sequence diagram was generated with EventStudio System Designer (<http://www.EventHelix.com/EventStudio>).